

THIS DRAWING IS UNPUBLISHED. RELEASED FOR PUBLICATION
 © COPYRIGHT - BY TYCO ELECTRONICS CORPORATION. ALL RIGHTS RESERVED.

LOC	DIST	REVISIONS					
G	14	P	LTR	DESCRIPTION	DATE	DWN	APVD
			W1	REV PER ECR 06-019936	30OCT06	JR	TM

- △ 1 FOR 9.53 [.375] MAX WIRE INSULATION DIA
- △ 2 SUPERSEDED BY 35653
- △ 3 MATERIAL: BODY; COPPER PER ASTM B152
INSULATION; NYLON
COLOR; NATURAL
- △ 4 FINISH: BODY; TIN PL. PER ASTM B545

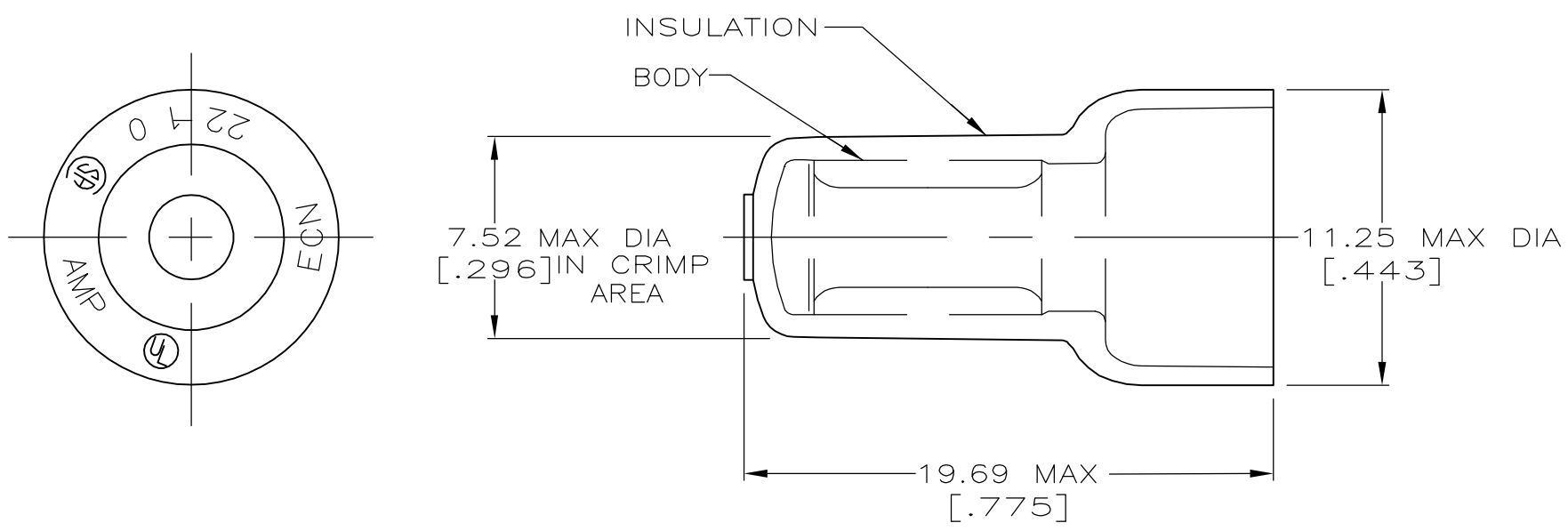

AMP WIRE RANGE	Listed	LR7189 Certified
22-10 AWG SOLID OR STRANDED	22-10 AWG SOLID OR STRANDED	22-10 AWG SOLID OR STRANDED

25	LOOSE PC,BAG	8-35653-5
5	LOOSE PC,BLS	8-35653-4
100	LOOSE PC,BOX	8-35653-1
10000	SPECIAL PKG,	2-35653-2 △ 2
1500	TAPE MOUNTED	2-35653-1
1000	LOOSE PIECE	35653
QTY	DESCRIPTION	PART NO

AMP INCORPORATED CUSTOMER SERVICE SYSTEMS		MAX RECOMMENDED OPERATING TEMPERATURE: 105° C MAX	THIS DRAWING IS A CONTROLLED DOCUMENT.		DWN G KRUPER 1/93	tyco Tyco Electronics Corporation			
FOR ADDITIONAL PRODUCT INFORMATION OR COPIES OF DRAWINGS AND TECHNICAL DOCUMENTS	PRODUCT INFORMATION CENTER 1-800-522-6752	VOLTAGE RATING: 300V MAX	DIMENSIONS: INCHES	TOLERANCES UNLESS OTHERWISE SPECIFIED:	CHK R HERSEY 1/93	Harrisburg, Pa 17105-3608			
FOR APPLICATION TOOLING INFORMATION	TOOLING ASSISTANCE CENTER 1-800-722-1111	CIRCULAR MIL AREA: 1.65-6.64mm ² [3248-13100] SOLID OR STRANDED		0 PLC ± - 1 PLC ± - 2 PLC ± 0.20[.008] 3 PLC ± - 4 PLC ± - ANGLES ± -	APVD M ELLIS 1/93	NAME SPLICE, WIRE, CLOSED END			
FOR ORDER ENTRY	1-800-526-5142	THIS DRAWING IS A CONTROLLED DOCUMENT FOR AMP INCORPORATED. IT IS SUBJECT TO CHANGE AND THE CONTROLLING ENGINEERING ORGANIZATION SHOULD BE CONTACTED FOR THE LATEST REVISION.	MATERIAL - △ 3	FINISH - △ 4	PRODUCT SPEC -	SIZE A3	CAGE CODE 00779	DRAWING NO C-35653	RESTRICTED TO -
CUSTOMER DRAWING					WEIGHT -	SCALE 4:1	SHEET 1 OF 1	REV W1	